

INSTALLATION INSTRUCTIONS

MODEL RMS



Please read and save these instructions. Read carefully before attempting to assemble, install, operate or maintain the product described. Protect yourself and others by observing all safety information. Failure to strictly follow all instructions may result in DEATH or SERIOUS INJURY. Before servicing, shut down and physically lock-out the conveyor system. Disconnect power before servicing.



Conveyor Components Company

Division of Material Control, Inc. | Crosswell, Michigan U.S.A.

MODEL RMS NON-CONTACT MOTION CONTROL

TOOLS NEEDED

- Adjustable Wrenches (size varies with model)
 - RMS-8S 9/16" [13 mm]
 - RMS-12S 11/16" [17 mm]
 - RMS-18S 1" [24 mm]
 - RMS-30S 1-7/16" [36 mm]
- Precision Screwdriver (included)
- 1/8" Flathead Screwdriver
- Large Screwdriver
- Electric Drill
- Tape Measure
- Pencil, marker or scribing tool

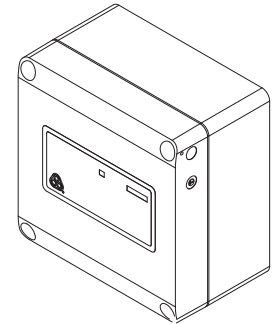

DIMENSIONS

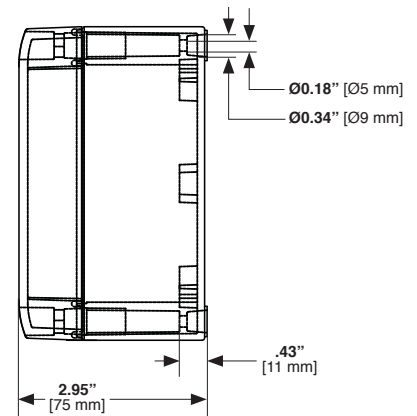
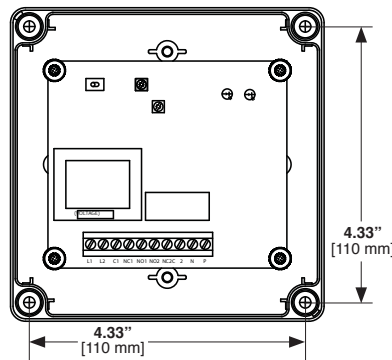
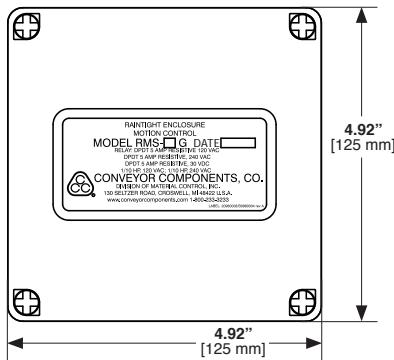

INSTALLATION



WARNING! Failure to strictly follow all instructions may result in DEATH or SERIOUS INJURY. Before servicing, shut down and physically **LOCK-OUT** the conveyor system. Disconnect power before servicing.

LOCATION AND MOUNTING:

The Model RMS-G is equipped with a NEMA Type 4X enclosure, and can be mounted using screws through the corner holes of the enclosure. For normal sensor installations, use 1/4" diameter machine bolts with lock washers (not included) through the two mounting holes in the base of the mounting bracket. The sensor should be mounted at a right angle to the object to be sensed at a distance as indicated in Table 1.

WIRING:

Wire input power from source to terminals L1 and L2. The output of the Model RMS-G is a DP/DT relay. There are two sets of output contacts. Each set includes normally open, normally closed, and common. As a result, the unit can be used to control two separate circuits such as a motor starter and a signal light.

SIGNAL SET POINTS, UNDERSPEED:

1. Select the speed range required by changing the switch to LOW for 2 to 120 PPM (pulses per minute), MEDIUM for 20 to 1200 PPM, and HIGH for 200 to 12,000 PPM.
2. Turn the set point potentiometer to the counterclockwise stop. With signal present from the sensor and at normal operating speed, the yellow pulse indicator L.E.D. should blink. The green relay indicator L.E.D. should turn on indicating that the output relay is energized.
3. Slowly turn the set point adjustment screw clockwise until the output relay de-energizes (a "click" will occur at this point). The green L.E.D. will turn off.
4. Back up until the output relay energizes. Thus, when speed drops below the set point, the green L.E.D. should turn off indicating that the output relay is de-energized.
5. If the normal operating speed exceeds 120 PPM for the LOW or 1200 PPM for the MEDIUM or 12000 PPM for the HIGH, the unit should be adjusted as follows. Turn the set point adjustment screw clockwise until it reaches the stop. When the speed drops below 120 PPM for the LOW or 1200 PPM for the MEDIUM or 12000 PPM for the HIGH, the relay will energize.
6. Note: Typically, the motor contactor is wired in series with one of the N.O. output contacts; and an alarm is wired with one of the N.C. output contacts.

SIGNAL SET POINTS, OVERSPEED:

1. Select the speed range required by changing the switch to LOW for 2 to 120 PPM (pulses per minute), MEDIUM for 20 to 1200 PPM, and HIGH for 200 to 12,000 PPM.
2. Turn the set point potentiometer to the counterclockwise stop. With signal present from the sensor and at normal operating speed, the yellow pulse indicator L.E.D. should blink. The green relay indicator L.E.D. should turn on indicating that the output relay is energized.
3. Slowly turn the set point adjustment screw clockwise until the output relay de-energizes (a "click" will occur at this point). The green L.E.D. will turn off. With the potentiometer on that setting, if the speed increases the output relay will energize.
4. Note: Typically, the motor contactor is wired in series with one of the N.O. output contacts; and an alarm is wired with one of the N.C. output contacts.

TIME DELAY SETTING:

The Model RMS-G motion sensing control has a start-up delay that is adjustable up to 45 seconds. This setting should be set, depending on the application and the length of time it takes for the conveyor to reach its normal operating speed. This time delay takes effect upon power-up of the Model RMS-G after shutdown. AC power to the Model RMS-G must be interrupted for timer to be reset. This delay only affects start up, avoiding nuisance start up alarms.

SIGNAL SET POINTS: ZERO SPEED

1. Select the HIGHEST speed range possible for the application.
2. Turn the set point potentiometer slightly under the current running speed, as indicated by the green L.E.D. turning on, and then adjust the potentiometer slightly under this setting. If the speed drops below this set point, the output relay will de-energize.
3. Typically, the motor contact is wired in series with one of the N.O. output contacts, and an alarm is wired with one of the N.C. output contacts. NOTE: very slow speeds will cause a mechanical delay in the sensor operation, resulting in a longer time lapse before response.

Figure 1: Wiring Layout Models RMS-1G, RMS-2G, RMS-3G. These models are supplied with a time delay / set point adjusting tool.

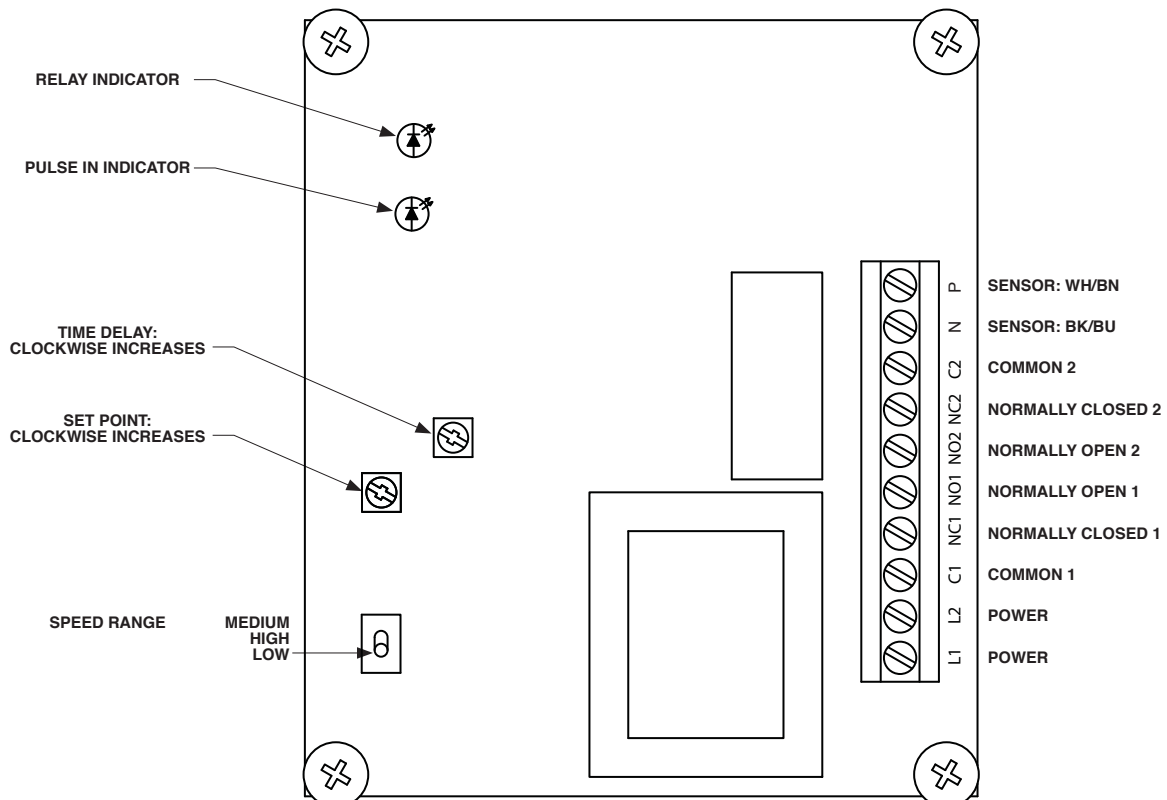

SPECIFICATIONS:

TABLE 1: MOTION SENSOR SPECIFICATIONS				
Part Number	RMS-8S	RMS-12S	RMS-18S	RMS-30S
Sensor Type	2 wire DC	2 wire DC	2 wire DC	2 wire DC
Body Diameter	8mm (0.31 in)	12mm (0.47 in)	18mm (0.71 in)	30mm (1.18 in)
Body Length	50mm (1.96 in)	71mm (2.80 in)	80mm (3.15 in)	81mm (3.19 in)
Thread Size	M8	M12	M18	M30
Cable Length	2m (6.6 ft)	2m (6.6 ft)	2m (6.6 ft)	2m (6.6 ft)
Sensing Range	1.0mm (0.04 in)	2.0mm (0.08 in)	5.0mm (0.20 in)	10mm (0.30 in)
Maximum Pulse Rate	1.5 KHz	1.5 KHz	1.0 KHz	0.6 KHz
Maximum Voltage	30 VDC	30 VDC	30 VDC	30 VDC
Maximum Current	100 MA	100 MA	100 MA	100 MA

TABLE 2: RMS-G CONTROL UNIT SPECIFICATIONS		
Model	Input	Features
RMS-1G	105-135 VAC, 50/60 Hz	Electronics and NEMA Type 4X Enclosure
RMS-2G	210-250 VAC, 50/60 Hz	Electronics and NEMA Type 4X Enclosure
RMS-3G	24 AC/DC	Electronics and NEMA Type 4X Enclosure
OUTPUT		DPDT relay to 5 Amp. Resistive at 120 volts A.C. DPDT relay to 5 Amp. Resistive at 240 volts A.C. DPDT relay to 5 Amp. Resistive at 30 volts D.C. 1/10 Horse Power at 120 volts A.C. 1/10 Horse Power at 240 volts A.C.
Operating Temperature Range		-50° F to +150° F
Repeatability		+2% maximum at constant voltage and temperature
Power Consumption		3 Watts
Pick-Up Point		3 Input Ranges at which relay will energize
LOW		2 to 120 PPM
MEDIUM		20 to 1200 PPM
HIGH		200 to 12000 PPM
Signal Point		Speed at which relay will de-energize. Recommended to be 15-20% lower than pick-up point. This will eliminate nuisance shutdowns.
Start-Up Delay		Adjustable up to 45 seconds
Enclosure		Plastic (Halogen-free Polycarbonate)
Weight		1 lb.
Size: RMS-1G, RMS-2G, RMS-3G		2.95" high x 4.92" wide x 4.92" long [75 x 125 x 125 mm]

Figure 2: Sensor Mounting Examples

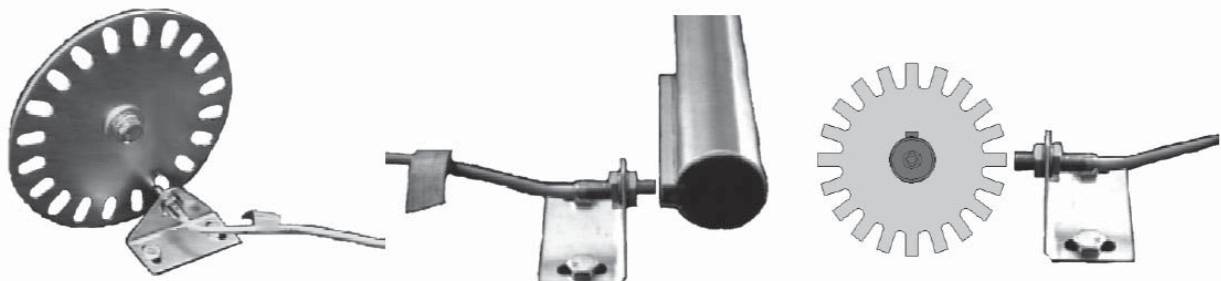

TROUBLE SHOOTING:

1. Issues and Solutions

TABLE 3	
Problem:	Solution:
No pulses from yellow pulse indicator LED.	Check power supply and voltage. Make sure there is a signal from the sensor. Check to see if the LED in the sensor is blinking.
Relay is not energized or de-energized when expected. (i.e. green relay indicator LED not on or off when expected).	Check power supply and voltage. Make sure there is a signal from the sensor. Check for proper set point. Check for proper speed setting. (Low, Medium, or High)
Alarm sounds when equipment is started.	Start-up delay setting may be too short: increase if needed. Check for proper connections between alarm and relay. AC power to the RMS-G must be interrupted for alarm to reset.
Alarm does not sound when expected.	Check power supply Check for proper connections between alarm and relay.
Equipment is not shut off when expected.	Check power supply. Check for proper connections between control circuit and relay.
Green LED changes state yet relay contacts do not transfer.	Relay contacts damaged or closed: replace electronics board.
Relay takes a long time to change state at very low speeds, especially when used as a zero speed switch.	NOTE: Very slow speed mechanically delays sensor operation, resulting in a longer response to changes. Use a higher speed range if possible. Increase target disc rotational speed with belt or chain drive. Use a multiplier sprocket to increase target disc RPM. Use highest range that includes alarm speed needed. Adjust time delay potentiometer slightly clockwise. Do not set the time delay pot completely CCW. Consult Factory.

2. Factory Assistance

If assistance is needed to locate difficulties with a unit, or you would like information about alternate control devices, please call the factory at 1-800-233-3233.

To Help solve a problem quickly, please have as much of the following information as possible when you make your call:

- *Model Number
- *Date Purchased
- *Brief application information
- *Brief description of problem

EQUIPMENT SHIPPED BACK TO THE FACTORY WITHOUT PROPER AUTHORIZATION WILL BE REFUSED AND RETURNED AT THE SHIPPER'S EXPENSE.

3. Warranty and Parts

Refer to Manufacturer's General Terms and Conditions of Sale for warranty information.

For electronics replacement, please contact our sales department for replacement parts and availability.



Conveyor Components Company

Division of Material Control, Inc. | Croswell, Michigan U.S.A.

(810) 679-4211 • conveyorcomponents.com
©Copyright Conveyor Components Company. 2020
Division of Material Control, Inc.

