



CONVEYOR COMPONENTS COMPANY

Division of Material Control, Inc.

130 Seltzer Road, PO Box 167 • Croswell, MI 48422 USA

PHONE: (810) 679-4211 • TOLL FREE (800) 233-3233 • FAX: (810) 679-4510

Email: info@conveyorcomponents.com • <http://www.conveyorcomponents.com>

MODEL FS FLOW CONTROL FOR BULK MATERIALS

WARNING:

DEATH or SERIOUS INJURY may occur.

Before installing or adjusting, shut down and physically lock-out the conveyor system.

A. HOW IT WORKS

The Model FS Flow Control is designed to produce a signal if the flow of material at any critical point is interrupted. This signal can then be used to correct the difficulty and/or warn the operator.

Several controls can be used, each one placed at critical points along the conveying system. A continuous flow of material past the control holds the paddle-shaft-counterweight assembly out of the actuated position. If the flow stops, then the paddle is allowed to pivot and then actuate the micro-switch. When this occurs, a signal is generated to start or stop supporting machinery, or to activate visual or audible alarm systems.

The Model FS control is also fully adjustable. The paddle and counterweight assemblies can be positioned at various points along the shaft and rotated to any angular position. The shaft itself can be adjusted laterally. Inside, the actuating cams can be rotated so that the micro-switch actuation will occur at pre-determined points.

This versatile control can be mounted on all types of conveyors and feeders; in discharge openings of bins, bunkers, or hoppers; in angled and vertical chutes; or in discharge chutes of any configuration. It is available with either a cast-iron or aluminum housing, and in standard or explosion proof models. The paddle and shaft are both made of stainless steel.

B. INSTALLATION INSTRUCTIONS

1. A cam (or two cams on the two micro-switch unit) on the shaft actuates the micro-switch. Loosening the cam(s) and the shaft locking collars permits the shaft to be moved laterally in the casting. The shaft locking collars must be positioned inside against the bushings, and along with the cams, tightened securely in place. The paddle sensor and counterweight can be positioned in various positions on the shaft, and must be tightened securely on the shaft. Use the 3/32" Allen wrench supplied with the control. Refer to figures 3 and 5.
2. The housing can be mounted in any position. The counterweight permits paddle operation in any position from vertical to horizontal. Refer to figure 6 for dimensions.
3. After mounting the unit, the cover should be removed to adjust the cam on the shaft to give micro-switch actuation at the desired point. Both the paddle and the counterweight may have to be loosened, rotated and re-tightened on the shaft to achieve proper actuation. Refer to figure 1 and 3 through 6.
4. The paddle or counterweight may be easily field altered to suit the application.
5. Note: TWIST WIRE TOGETHER BEFORE INSERTING IN TERMINAL (ENROULEZ LES FILS ENSEMBLE AVANT LES INTRODUITE DANS LA BORNE.).

6. Field wiring must meet or exceed the requirements of the National Electrical Code and any other agency or authority having jurisdiction over the installation. Conduit fittings must meet applicable CSA and UL standards. Refer to figures 1 through 5 for wiring information.

C. TECHNICAL INFORMATON

1. Individual Switch Contact Ratings:

SPDT switches:	DPDT switches:
20 Amps, 125/250/480 VAC	15 Amps, 125/250 VAC
10 Amps, 125 VAC 'L' (Tungsten)	N/A
1 hp, 125 VAC	3/4 hp, 125 VAC
2 hp, 250 VAC	1 1/2 hp, 250 VAC
1/2 Amp, 24 VDC	N/A
1/2 Amp, 125 VDC	N/A
1/4 Amp, 250 VDC	N/A

Note: Special units with gold plated micro-switch contacts rated 0.1 Amps at 125 VAC.

2. Conduit opening: One 3/4" NPT standard opening is built-in.
3. Actuating System:
Paddle sensor is stainless steel with stainless steel shaft with zinc plated steel counterweight.
4. External Hardware: stainless steel
5. Operating Temperature Range (ordinary locations): -50°C to 65°C; -58°F to 150°F
6. Ambient Temperature Range (hazardous locations units): -50°C to 40°C; -58°F to 104°F
7. Enclosure Ratings:

FS-1, FS-2, FS-4, FS-5:
c-UL-US Listed Types 3S, 4, 4X & 5

FS-1X, FS-2X, FS-4X, FS-5X:
c-UL-US Listed Class I, Groups C & D; Class II, Groups E, F & G; Class III Hazardous Locations

FS-1D, FS-2D, FS-4D, FS-5D:
c-UL-US Listed Types 3S, 4, 4X & 5; Class II, Groups E, F & G; Class III Hazardous Locations

D. WIRING

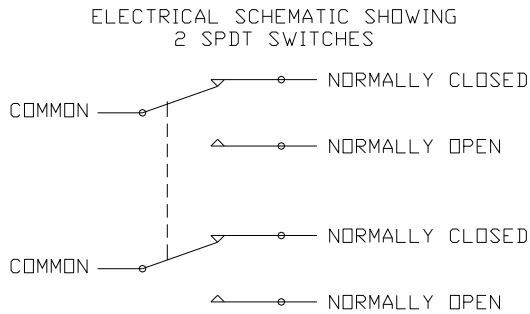

Figure 1: SPDT 2-Switch Schematic

ELECTRICAL SCHEMATIC SHOWING 2 DP/DT SWITCHES

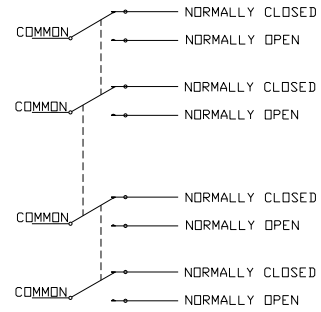

Figure 2: DPDT 2-Switch Schematic

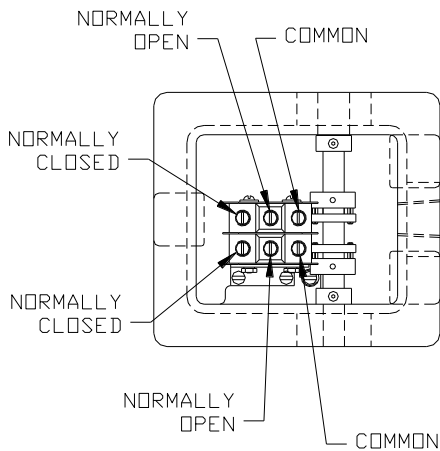

Figure 3: Terminal Identification (SPDT)

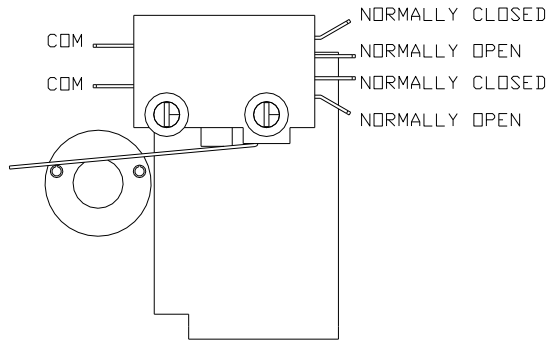
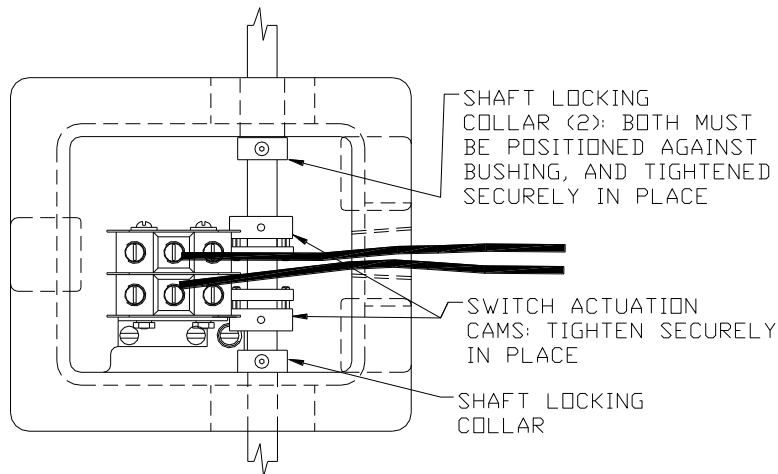

Figure 4: Terminal Identification (DPDT)

To properly wire to the micro-switches on the model FS, route incoming wires over the shaft and micro-switches. Avoid contact with the micro-switch levers and other moving parts inside enclosure. For DPDT switches, use hand crimp tool 0640014100 or crimp head 0640054100 for AT-200 pneumatic hand tool to attach insulated, flag quick-disconnects to wires.

Figure 5: Wire Routing, Model FS-2 shown



E. DIMENSIONS

Figure 6: Dimensions and Mounting, Model FS-2 shown

